

# Explosion Proof Servo Motors



ENGINEERING YOUR SUCCESS.



**WARNING – USER RESPONSIBILITY**

**FAILURE OR IMPROPER SELECTION OR IMPROPER USE OF THE PRODUCTS DESCRIBED HEREIN OR RELATED ITEMS CAN CAUSE DEATH, PERSONAL INJURY AND PROPERTY DAMAGE.**

- This document and other information from Parker-Hannifin Corporation, its subsidiaries and authorized distributors provide product or system options for further investigation by users having technical expertise.
- The user, through its own analysis and testing, is solely responsible for making the final selection of the system and components and assuring that all performance, endurance, maintenance, safety and warning requirements of the application are met. The user must analyze all aspects of the application, follow applicable industry standards, and follow the information concerning the product in the current product catalog and in any other materials provided from Parker or its subsidiaries or authorized distributors.
- To the extent that Parker or its subsidiaries or authorized distributors provide component or system options based upon data or specifications provided by the user, the user is responsible for determining that such data and specifications are suitable and sufficient for all applications and reasonably foreseeable uses of the components or systems.

**Standards**

**Hazardous Areas Classification .....6**

**Compliance with China Standards.....7**

**Operating category and marking of EY servomotors .....8**

**Operating category and marking of EX servomotors .....9**

**Explosion Proof Motor for Zone 2 - EY Series**



**Overview..... 11**

**EY Servo Motors - CE Marked for Explosive Atmospheres .....12**

**Drive Associations..... 14**

**Dimensions ..... 16**

**Order Code..... 17**

**Explosion Proof Motor for Zone 1 - EX Series**



**Overview..... 19**

**EX Servo Motors - CE Marked for Explosive Atmospheres .....20**

**Drive Associations.....22**

**Dimensions (Resolver Version) .....24**

**Order Code.....26**

**Additional Information.....28**

    Feedback Sensors.....28

    Shaft Loads for CE Motors.....28

**ATEX Gearboxes GXA Series**



**Overview.....31**

**Technical Characteristics.....32**

**Dimensions .....35**

**Gearbox Combinations.....37**

**Order Code.....38**



Series	EY		EX	
				
	<a href="http://www.parker.com/eme/ey">www.parker.com/eme/ey</a>		<a href="http://www.parker.com/eme/ex">www.parker.com/eme/ex</a>	
	page 11		page 19	
Marking	ATEX		ATEX/IECEX, KOSHA	
EX Zone	Zone 2 / 22		Zone 1 / 21	
Classification	Gas or Dust		Gas or Dust	
Torque	1.8 to 41 Nm		1.75 to 35 Nm	
Max Speed	6 800 min <sup>-1</sup>		6 800 min <sup>-1</sup>	
Ingress protection level	IP65		IP65	
Power Supply	230 - 400 VAC		230 - 400 VAC	
Conformance	ATEX 2014/34/EU Directive		ATEX 2014/34/EU Directive	
			CNCA-C23-01 2019 CNEX-C2301-2019	

# Standards

## Hazardous Areas Classification

### Dangerous Areas Identification

European directive 99/92/EC makes explicit the responsibility of employers to protect employees who may be exposed to risk of ATEX environments (Explosive Atmosphere). The employer must assess the risk and classify potentially dangerous areas. Equipment and materials must also be suited for use in dangerous areas in accordance with ATEX directive 2014/34/EU.

Hazard	Permanent	EX Series	
		Occasional	EY Series Unusual
Definition	Explosive atmospheres present continuously, for long periods or frequently	Explosive atmospheres are likely to occur	Explosive atmospheres are unlikely to occur or present only infrequently and for a short period only
Gas and vapour	Zone 0	Zone 1	Zone 2
Dust	Zone 20	Zone 21	Zone 22
Category	1 Very high level of protection	2 High level of protection	3 Normal level of protection

 Suitable for ATEX/IECEX Parker servomotors

### Classification of common combustible gases and vapours according to temperature class and explosion group

T° Class	Group	EX Series					
		EY Series			T4	T5	T6
		T1	T2	T3	T4	T5	T6
I	I	Methane					
		Acetic acid Acetone Ammonia Benzene Carbon monoxide Ethane Ethyl... Methane Methanol Methyl... Naphtalene Propane Toluene Xylene	Butyl acetate Amylic alcohol Liquefied gas Natural gas Butane Ethyl alcohol	Cyclohexane Cyclohexanol Diesel fuels Gasoline Heptane Hexane Pentane Petroleum (depending on composition)	Acetaldehyde Ether		
		Coke gas	Butadiene Ethylene Ethylbenzene Ethylene oxide	Hydrogen sulphide Isoprene Petroleum (depending on composition)	Ethyl ether		
		Hydrogen	Acetylene				Carbon disulphide Ethyl nitrate

## Compliance with China Standards



<b>Marking</b>	CCC
<b>Conformance</b>	CNCA-C23-01 2019 CNEX-C2301-2019
<b>Standards</b>	GB3836.1-2010 GB3836.2-2010 GB12476.1-2013 GB12476.5-2013
<b>Marking</b>	Ex d IIB T4 Gb IP64 (Gas) Ex d IIB T4 Gb, Ex tD A21 IP65 T135°C (Gas or Dust)
<b>Ingress protection level</b>	IP65 (Gas or dust)

CCC: "CCC" motors have exactly the same construction as IECEx motors (with the exception of a specific nameplate). They are intended for use in the same areas (gas or dust) and have the same degree of safety. Refer to standards GB3836.1-2010, GB3836.2-2010, GB12476.1-2013, GB12476.5-2013 for more details.

## Operating category and marking of EY servomotors



### ATEX gazeous atmospheres

II 3 G Ex nA IIC T3 Gc IP65

II	3	G	Ex	nA	II	C	T3*	Gc	IP65	
I Mine	M1 Very high level of protection	G Gas Vapour	Protection against explosions	nC Equipment with protection against sparks	I Mine	Methane	T1 450 °C	Ma Very high level of protection	IP65	
	M2 High level of protection			nR Equipment with restricted breathing			T2 300 °C	Mb High level of protection		
II Surface	1 Very high level of protection			nA Equipment not generating sparks	II Surface	A Propane	T3 200 °C	Ga Very high level of protection		
	2 High level of protection						B Ethylene	T4 135 °C		Gb High level of protection
	3 Normal level of protection						C Hydrogen Acetylene	T5 100 °C		Gc Normal level of protection
								T6 85 °C		

\* Maximum surface temperature

### ATEX dusty atmospheres

II 3 GD Ex nA IIC T3 Gc IP65 / Ex tc IIIC T200°C Dc IP65

II	3	D	Ex	tc	III	C	T3*	Dc	IP65
I Mine	M1 Very high level of protection	D Dust	Protection against explosions	ta Protection by enclosure	III Dust	A Combustible flying	T1 450 °C	Ma Very high level of protection	IP65
	M2 High level of protection			tb/tc Protection by enclosure			T2 300 °C	Mb High level of protection	
II Surface	1 Very high level of protection			pb/pc pressurized enclosure		T3 200 °C	Da Very high level of protection		
	2 High level of protection			ia/ib/ic intrinsic safety				T4 135 °C	
	3 Normal level of protection			ma/mb/mc Encapsulation	T5 100 °C	Dc Normal level of protection			
							T6 85 °C		

Suitable for ATEX Parker EY servomotors



## Operating category and marking of EX servomotors

### ATEX/IECEX gaseous atmospheres



II 2 G Ex db IIB T4 Gb IP65 – Group IIA or IIB – category 2G – zone 1 and 2.

II	2	G	Ex	db	II	B	T4*	Gb	IP65
I Mine	M1 Very high level of protection	G Gas Vapour	Protection against explosions	o Oil immersion	I Mine	Methane	T1 450 °C	Ma Very high level of protection	IP65
	M2 High level of protection			p Pressurized apparatus			T2 300 °C	Mb High level of protection	
II Surface	1 Very high level of protection			db Flameproof enclosure	II Surface	A Propane	T3 200 °C	Ga Very high level of protection	
	2 High level of protection			e Increased safety		B Ethylene	T4 135 °C	Gb High level of protection	
	3 Normal level of protection			m Encapsulation		C Hydrogen Acetylene	T5 100 °C	Gc Normal level of protection	
				i Intrinsic safety			T6 85 °C		

\* Maximum surface temperature

### ATEX/IECEX dusty atmospheres

II 2 D Ex tb III C T135 °C Db IP65 - category 2D – zone 21 and 22

II	2	D	Ex	tb	III	C	T135°C*	Db	IP65	
I Mine	M1 Very high level of protection	D Dust	Protection against explosions	ta Protection by enclosure	III Dust	A Combustible flying	T1 450 °C	Ma Very high level of protection	IP65	
	M2 High level of protection			tb/tc Protection by enclosure			T2 300 °C	Mb High level of protection		
II Surface	1 Very high level of protection			pb/pc pressurized enclosure		III Dust	B Non-conductive dust	T3 200 °C		Da Very high level of protection
	2 High level of protection			ia/ib/ic intrinsic safety				T4 135 °C		Db High level of protection
	3 Normal level of protection			ma/mb/mc Encapsulation			C Conductive dust	T5 100 °C		Dc Normal level of protection
								T6 85 °C		

 Suitable for ATEX/IECEX Parker EX servomotors



# Explosion Proof Motor for Zone 2 - EY Series

## Overview

### Description

The EY series is a range of permanent magnet explosion-proof brushless servo motors designed for use in **explosive atmospheres in zone 2** for gas and dust at 40°C or 60°C ambient temperature. The EY series of servo motors are characterized by excellent motion quality, dynamic acceleration/deceleration capabilities and high torque output over a wide speed range. Various winding variants and numerous options are available to offer maximum flexibility. This range is in accordance with the European (CE) and International safety standards.

### Advantages

- Brushless servo motors with explosion proof certification from a notified body.
- Conforming with CE/ATEX and International safety standard
- For an ambient temperature at 40°C or 60°C
- For gas and dust explosive atmospheres
- High precision
- High motion quality
- High dynamic performance
- Low cogging
- Compactness and robustness
- Maintenance free
- High power density (6 kW in a 155 square frame)
- Compatible with all popular drives

### Applications

- Printing machinery
- Paint spray equipments
- Chemical, petro-chemical and pharmaceutical industries
- Robot applications
- Special machines
- Cleaning applications
- Actuator for valve in Energy applications
- Waste processing plants

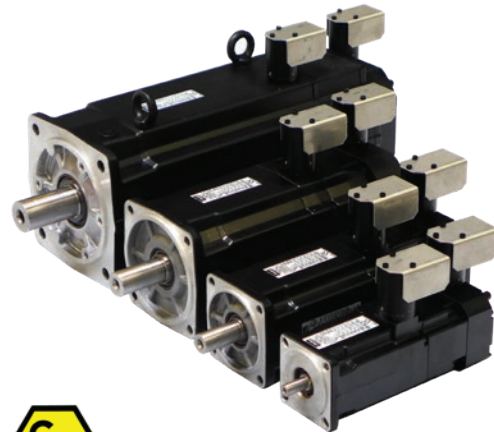

### Technical characteristics

<b>Motor type</b>	Permanent magnet synchronous motors
<b>Frame size</b>	70 - 155 mm
<b>Torque range</b>	1.8 to 41 Nm
<b>Speed range</b>	Up to 6800 min <sup>-1</sup>
<b>Number of poles</b>	10
<b>Mounting</b>	Flange with smooth holes
<b>Marking</b>	CE / ATEX
<b>Voltage supply</b>	230 / 400 VAC
<b>Conformance</b>	ATEX 2014/34/EU Directive IEC/EN60034-1 IEC/EN60034-5 IEC/EN60079-0 IEC/EN60079-15 (Gas) IEC/EN60079-31 (Dust)
<b>Classification</b>	II 3 GD Ex nA IIC T3 Gc IP65 / Ex tc IIIC T200°C Dc IP65 (Gas or dust)
<b>Ingress protection level</b>	IP65
<b>Connections</b>	Connector

# EY Servo Motors - CE Marked for Explosive Atmospheres

## Technical Data

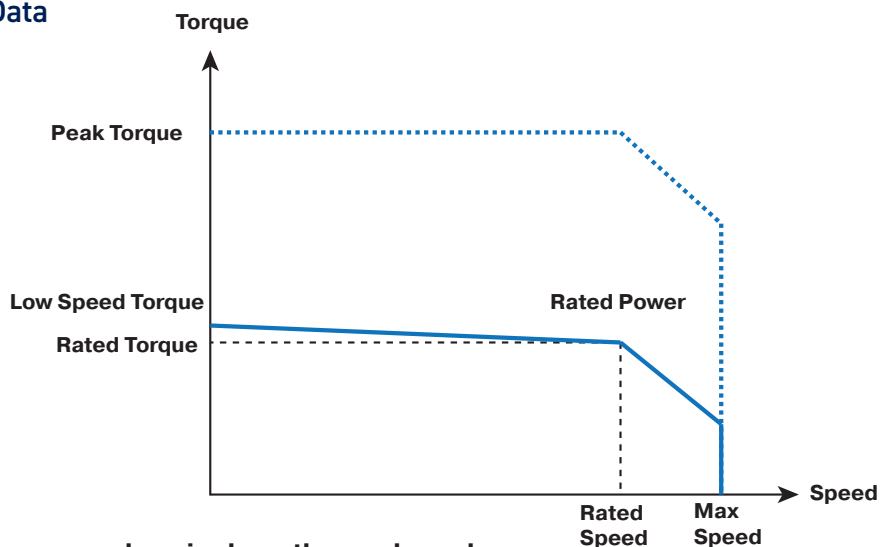

### 230 VAC power supply - single or three-phased

Motor	Rated Power P <sub>n</sub>	Rated Torque M <sub>n</sub>	Rated Speed N <sub>n</sub>	Rated Current I <sub>n</sub>	Low speed torque M <sub>0</sub>	Low Speed Current I <sub>0</sub>	Peak Torque M <sub>peak</sub>	Peak Current I <sub>peak</sub>	Max. Speed N <sub>max</sub>
	[kW]	[Nm]	[rpm]	[Arms]	[Nm]	[Arms]	[Nm]	[Arms]	[rpm]
<b>40°C ambient temperature</b>									
EY310EAP	0.46	1.9	2300	1.4	2	1.4	4.7	3.6	2300
EY310EAK	0.72	1.7	4000	2.2	2	2.5	4.72	6.25	4000
EY420EAP	0.9	3.8	2300	2.7	4	2.8	9.47	7.03	2300
EY420EAJ	1.4	3.4	4000	4.2	4	4.9	9.47	12.2	4000
EY430EAL	1.2	5.0	2300	3.5	5.5	3.8	13.1	9.4	2300
EY430EAF	1.7	4.1	4000	5.1	5.5	6.6	13.1	16.5	4000
EY620EAV	0.9	7.9	1100	2.8	8	2.8	18.9	7.04	1100
EY620EAR	1.7	7.4	2200	5.0	8	5.3	18.9	13.2	2200
EY630EAR	1.7	11.3	1450	5.2	12	5.5	28.4	13.7	1450
EY630EAN	2.5	10.5	2300	7.3	12	8.3	28.4	20.6	2300
EY820EAR	3.3	14.5	2200	9.7	16	10.7	36.8	26.7	2200
EY840EAK	4.9	23.5	2000	13.7	28	16.2	65.8	40.4	2000
EY860EAJ	5.2	34.4	1450	14.9	41	17.7	96.7	44.2	1450
<b>60°C ambient temperature</b>									
EY310EAP	0.40	1.7	2300	1.2	1.8	1.3	4.3	3.21	2300
EY310EAK	0.61	1.5	4000	1.9	1.8	2.3	4.3	5.62	4000
EY420EAP	0.8	3.1	2300	2.2	3.5	2.5	8.39	6.14	2300
EY420EAJ	1.1	2.7	4000	3.4	3.5	4.3	8.39	10.6	4000
EY430EAL	1.1	4.4	2300	3.1	5.0	3.4	12	8.54	2300
EY430EAF	1.4	3.4	4000	4.2	5.0	6.0	12	15	4000
EY620EAV	0.8	7.0	1100	2.5	7.2	2.5	17.3	6.33	1100
EY620EAR	1.5	6.4	2200	4.3	7.2	4.8	17.3	11.9	2200
EY630EAR	1.5	10.1	1450	4.6	10.8	4.9	25.9	12.3	1450
EY630EAN	2.2	9.1	2300	6.3	10.8	7.4	25.9	18.6	2300
EY820EAR	2.7	11.7	2200	7.9	14.0	9.3	32.9	23.3	2200
EY840EAK	3.9	18.4	2000	10.8	25.5	14.7	60.8	36.8	2000
EY860EAJ	4.4	29.0	1450	12.6	37.0	15.9	88.5	39.8	1450

**400 VAC power supply - three-phased**

Motor	Rated Power Pn	Rated Torque Mn	Rated Speed Nn	Rated Current In	Low speed torque Mo	Low Speed Current Io	Peak Torque M peak	Peak Current I peak	Max. Speed N max
	[kW]	[Nm]	[rpm]	[Arms]	[Nm]	[Arms]	[Nm]	[Arms]	[rpm]
<b>40°C ambient temperature</b>									
EY310EAP	0.72	1.7	4000	1.3	2	1.4	4.72	3.58	4000
EY310EAK	0.87	1.2	6800	1.6	2	2.5	4.72	6.25	6800
EY420EAP	1.1	3.6	3000	2.6	4	2.8	9.47	7.03	3000
EY420EAJ	1.7	2.6	6000	3.4	4	4.9	9.47	12.2	6000
EY430EAL	1.7	4.1	4000	2.9	5.5	3.8	13.1	9.4	4000
EY430EAF	1.6	2.7	5800	3.4	5.5	6.6	13.1	16.5	5800
EY620EAV	1.6	7.5	2000	2.7	8	2.8	18.9	7.04	2000
EY620EAR	2.5	6.2	3900	4.2	8	5.3	18.9	13.2	3900
EY630EAR	2.8	10.0	2700	4.6	12	5.5	28.4	13.7	2700
EY630EAN	3.3	7.9	4000	5.6	12	8.3	28.4	20.6	4000
EY820EAR	5.3	12.9	3900	8.8	16	10.7	36.8	26.7	3900
EY840EAK	6.8	18.6	3500	11.0	28	16.2	65.8	40.4	3500
EY860EAJ	6.3	23.0	2600	10.2	41	17.7	96.7	44.2	2600
<b>60°C ambient temperature</b>									
EY310EAP	0.61	1.5	4000	1.1	1.8	1.3	4.3	3.21	4000
EY310EAK	0.67	0.9	6800	1.3	1.8	2.3	4.3	5.62	6800
EY420EAP	0.9	3.0	3000	2.1	3.5	2.5	8.39	6.14	3000
EY420EAJ	1.2	2.0	6000	2.6	3.5	4.3	8.39	10.6	6000
EY430EAL	1.4	3.4	4000	2.4	5.0	3.4	12	8.54	4000
EY430EAF	1.3	2.6	4900	3.3	5.0	6.0	12	15	4900
EY620EAV	1.4	6.5	2000	2.3	7.2	2.5	17.3	6.33	2000
EY620EAR	2.0	4.9	3900	3.3	7.2	4.8	17.3	11.9	3900
EY630EAR	2.4	8.4	2700	3.9	10.8	4.9	25.9	12.3	2700
EY630EAN	2.4	5.8	4000	4.1	10.8	7.4	25.9	18.6	4000
EY820EAR	3.2	7.8	3900	5.4	14.0	9.3	32.9	23.3	3900
EY840EAK	3.9	14.1	2600	8.4	25.5	14.7	60.8	36.8	2600
EY860EAJ	4.8	21.8	2100	9.6	37.0	15.9	88.5	39.8	2100

## Drive Associations

### 230 VAC power supply

Motor	Associated Drive Sizes <sup>(1)</sup>			
	PSD1 <sup>(2)</sup>	Compax3	SLVD-N	AC890
<b>With 40°C ambient temperature - 230 VAC power supply</b>				
EY310EAP	PSD1SW1200...	C3S025V2...	SLVD2N...	890SD-231300B...
EY310EAK	PSD1SW1300...	C3S025V2...	SLVD5N...	890SD-231550B...
EY420EAP	PSD1SW1300...	C3S063V2...	SLVD5N...	890SD-231700B...
EY420EAJ	PSD1SW1300...	C3S063V2...	SLVD5N...	890SD-231700B...
EY430EAL	PSD1SW1300...	C3S063V2...	SLVD5N...	890SD-231700B...
EY430EAF	-	C3S100V2...	SLVD7N...	890SD-232165B...
EY620EAV	PSD1SW1300...	C3S063V2...	SLVD5N...	890SD-231550B...
EY620EAR	-	C3S063V2...	SLVD7N...	890SD-231700B...
EY630EAR	-	C3S063V2...	SLVD7N...	890SD-232165B...
EY630EAN	-	C3S100V2...	SLVD10N...	890SD-232165B...
EY820EAR	-	C3S150V2...	SLVD15N...	890SD-232240C...
EY840EAK	-	-	-	890SD-232240C...
EY860EAJ	-	-	-	890SD-232240C...
<b>With 60°C ambient temperature - 230 VAC power supply</b>				
EY310EAP	PSD1SW1200...	C3S025V2...	SLVD2N...	890SD-231300B...
EY310EAK	PSD1SW1300...	C3S025V2...	SLVD5N...	890SD-231550B...
EY420EAP	PSD1SW1300...	C3S063V2...	SLVD5N...	890SD-231550B...
EY420EAJ	PSD1SW1300...	C3S063V2...	SLVD5N...	890SD-231700B...
EY430EAL	PSD1SW1300...	C3S063V2...	SLVD5N...	890SD-231700B...
EY430EAF	-	C3S063V2...	SLVD7N...	890SD-232165B...
EY620EAV	PSD1SW1300...	C3S025V2...	SLVD5N...	890SD-231550B...
EY620EAR	-	C3S063V2...	SLVD5N...	890SD-231700B...
EY630EAR	-	C3S063V2...	SLVD5N...	890SD-231700B...
EY630EAN	-	C3S100V2...	SLVD10N...	890SD-232165B...
EY820EAR	-	C3S100V2...	SLVD10N...	890SD-232165B...
EY840EAK	-	C3S150V2...	SLVD15N...	890SD-232240C...
EY860EAJ	-	-	-	890SD-232240C...

<sup>(1)</sup>Ambient temperature for the drives is 40°C

<sup>(2)</sup>PSD drive with optional resolver board only

**400 VAC power supply**

Motor	Associated Drive Sizes <sup>(1)</sup>			
	PSD1 <sup>(2)</sup>	Compax3	AC890	AC30V
<b>With 40°C ambient temperature - 400 VAC power supply</b>				
EY310EAP	PSD1MW1300...	C3S015V4...	890SD-531200B...	31V-4D-0004
EY310EAK	PSD1MW1300...	C3S038V4...	890SD-531350B...	31V-4D-0004
EY420EAP	PSD1MW1300...	C3S038V4...	890SD-531450B...	31V-4D-0004
EY420EAJ	PSD1MW1300...	C3S075V4...	890SD-532100B...	31V-4D-0008
EY430EAL	PSD1MW1300...	C3S038V4...	890SD-532100B...	31V-4D-0005
EY430EAF	PSD1MW1400...	C3S075V4...	890SD-532120B...	31V-4D-0008
EY620EAV	PSD1MW1300...	C3S038V4...	890SD-531450B...	31V-4D-0004
EY620EAR	PSD1MW1400...	C3S075V4...	890SD-532100B...	31V-4D-0008
EY630EAR	PSD1MW1400...	C3S075V4...	890SD-532100B...	31V-4D-0008
EY630EAN	PSD1MW1600...	C3S150V4...	890SD-532120B...	31V-4D-0010
EY820EAR	PSD1MW1600...	C3S150V4...	890SD-532160B...	31V-4D-0012
EY840EAK	PSD1MW1800...	C3S300V4...	890SD-53216SB...	31V-4E-0023
EY860EAJ	PSD1MW1800...	C3S300V4...	890SD-532240C...	31V-4E-0023
<b>With 60°C ambient temperature - 400 VAC power supply</b>				
EY310EAP	PSD1MW1300...	C3S015V4...	890SD-531200B...	31V-4D-0004
EY310EAK	PSD1MW1300...	C3S038V4...	890SD-531350B...	31V-4D-0004
EY420EAP	PSD1MW1300...	C3S038V4...	890SD-531450B...	31V-4D-0004
EY420EAJ	PSD1MW1300...	C3S075V4...	890SD-531600B...	31V-4D-0006
EY430EAL	PSD1MW1300...	C3S038V4...	890SD-531450B...	31V-4D-0005
EY430EAF	PSD1MW1400...	C3S075V4...	890SD-532100B...	31V-4D-0008
EY620EAV	PSD1MW1300...	C3S038V4...	890SD-531350B...	31V-4D-0004
EY620EAR	PSD1MW1300...	C3S075V4...	890SD-532100B...	31V-4D-0008
EY630EAR	PSD1MW1300...	C3S075V4...	890SD-532100B...	31V-4D-0008
EY630EAN	PSD1MW1400...	C3S075V4...	890SD-532120B...	31V-4D-0010
EY820EAR	PSD1MW1600...	C3S150V4...	890SD-532160B...	31V-4D-0012
EY840EAK	PSD1MW1600...	C3S150V4...	890SD-53216SB...	31V-4E-0023
EY860EAJ	PSD1MW1800...	C3S300V4...	890SD-53216SB...	31V-4E-0023

<sup>(1)</sup>Ambient temperature for the drives is 40°C

<sup>(2)</sup>PSD drive with optional resolver board only

## Dimensions

EY

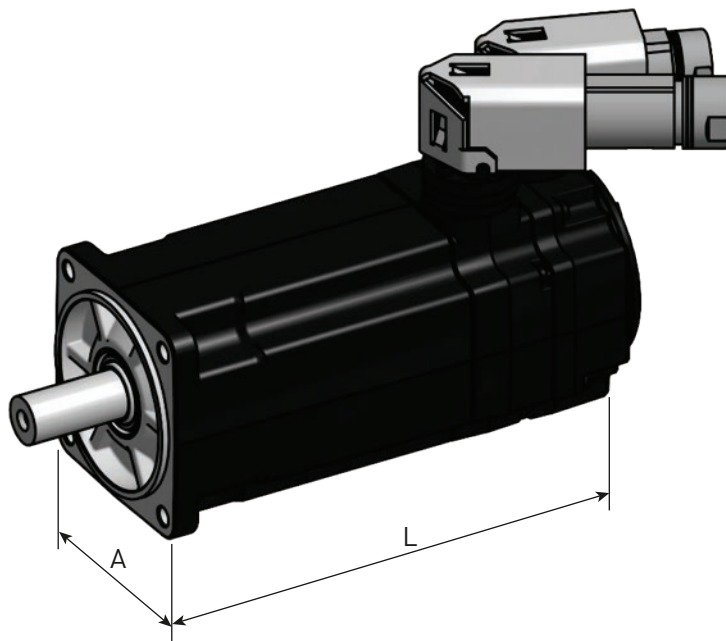

Motor	A	Mounting Flange centering / interaxis hole	Shaft diameter x length	Without Brake		With Brake	
	[mm]	[mm]	[mm]	L [mm]	Weight [kg]	L [mm]	Weight [kg]
EY310	71	60 / 75-80	11 x 23	159	2	207	2.4
EY420	91.5	80 / 100	19 x 40	181	3.7	232	4.5
EY430				206	4.6	257	5.4
EY620	121	110 / 130	24 x 50	195	6.9	249	8
EY630				224	8.8	278	10
EY820	155	130 / 165	32 x 58	213	13	279	16.5
EY840				273	20	339	23.5
EY860				333	27	399	30.5



# Order Code

## EY Motors

	1	2	3	4	5	6	7	8	9	10
Order example	EY	3	10	E	A	K	B	7	1	10

<b>1</b>	<b>Product Series</b>
EY	Atex servo motor Zone 2
<b>2</b>	<b>Motor size</b>
3	71 mm square
4	92 mm square
6	121 mm square
8	155 mm square
<b>3</b>	<b>Motor length</b>
10	up to 60 depending on size
<b>4</b>	<b>Fixed code</b>
E	ATEX motor
<b>5</b>	<b>Feedback sensor</b>
A	2 pole resolver
K	Without sensor
<b>6</b>	<b>Torque/Speed characteristics</b>
	see table "Technical data"
	...
<b>7</b>	<b>Painting</b>
B	Black RAL9005
<b>8</b>	<b>Electric connection</b>
7	Connector
<b>9</b>	<b>Brake and thermal sensor option*</b>
	PTC on power connector (AC890,AC30V,...)
1	PTC sensor
4	PTC sensor + brake
	PTC on feedback connector (PSD,Compax3,SLVD,...)
A	PTC sensor
D	PTC sensor + brake
<b>10</b>	<b>Mechanical interface</b>
10	IP65 with smooth shaft
11	IP65 with keyed shaft

\* other options on request

## Cables

### Motor cable

Drive	Cable reference	
	Current $\leq$ 12 A @40°C Current $\leq$ 9 A @60°C	Current $\leq$ 24 A @40°C Current $\leq$ 17 A @60°C
<b>PSD1S, PSD1M18</b>	CBM015HB-C04-D01-xxxx-00	CP1UQ2F1R0xxx
<b>PSD1M (except M18)</b>	CBM015HB-C04-D02-xxxx-00	CP1UQ2F1R0xxx
<b>Compax3</b>	CBM015HB-C04-D01-xxxx-00	CC3UQ2F1R0xxx
<b>SLVDN</b>	CS5UQ1F1R0xxx	CS5UQ2F1R0xxx
<b>AC890</b>	CS4UQ1F1R0xxx	CS4UQ2F1R0xxx
<b>AC30</b>	CS7UQ1F1R0xxx	CS7UQ2F1R0xxx

### Feedback cable (2 pole resolver)

Drive	Cable reference
<b>PSD1</b>	CBFRE0H0-C07-D03-xxxx-00
<b>Compax3</b>	CC3UA1F1R0xxx
<b>SLVDN</b>	CS5UA1F1R0xxx
<b>AC890</b>	CS4UA1F1R0xxx
<b>AC30</b>	CS7UA1F1R0xxx

For non-standard length cable with length different from: 3/5/10/15/20/25/30/50m please contact us.

# Explosion Proof Motor for Zone 1 - EX Series

## Overview

### Description

EX series is a range of permanent magnet servo motor designed for use in zone 1 explosive atmospheres. Featuring robust explosion-proof housings, EX motors are capable of bearing internal explosions with no risks of propagation to the neighbouring environment. Two versions are available, conforming with North American or European safety standards. EX servomotors are characterized by excellent motion quality, great acceleration / deceleration capabilities, and high torque output over a wide speed range. Various winding variants and numerous options are available to offer maximum flexibility.

### Advantages

- Servo motors with explosion proof enclosure "d"
- Conforming with CE/ATEX and IECEx
- For an ambient temperature at 40°C or 60°C
- For gas and dust explosive atmospheres
- High precision
- High motion quality
- High dynamic performance
- Low cogging
- Compactness and robustness
- Maintenance free
- High power density (6 kW in a 155 square frame)
- Compatible with all popular drives

### Applications

- Printing machinery
- Packaging, filling machines
- Painting robots
- Coating machines
- Chemical, petro-chemical and pharmaceutical industries
- Robot applications
- Special machines
- Cleaning applications
- Actuator for valve in Energy applications
- Waste processing plants

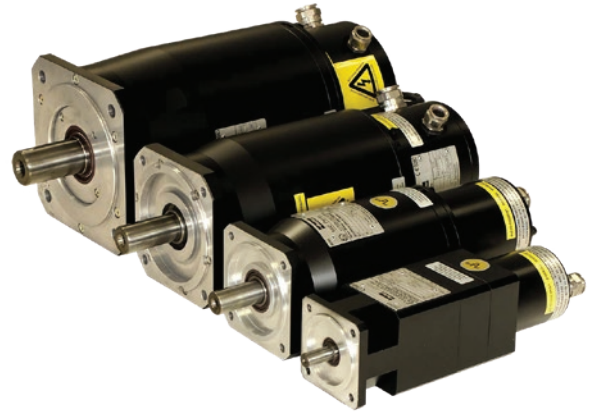

### Technical Characteristics - Overview

<b>Motor type</b>	Permanent magnet synchronous motors
<b>Number of poles</b>	10
<b>Torque range</b>	1.6 ... 35 Nm
<b>Speed range</b>	1100...7600 min <sup>-1</sup>
<b>Operating temperature</b>	Up to +40°C (standard) Up to +60°C (with derating)
<b>Marking*</b>	ATEX/IECEx, KOSHA
<b>Voltage supply</b>	230 / 400 VAC
<b>Conformance</b>	ATEX 2014/34/EU Directive  IEC/EN60079-0, IEC/EN60079-1 IEC/EN60079-31 standards
<b>Classification</b>	II 2GD Ex db IIB T4 Gb IP65 Ex tb IIIC T135 °C Db IP65 (Gas or Dust)
<b>Ingress protection level</b>	IP65
<b>Connections</b>	Cable glands

\* For CCC please see page 7

## EX Servo Motors - CE Marked for Explosive Atmospheres

### Technical Data

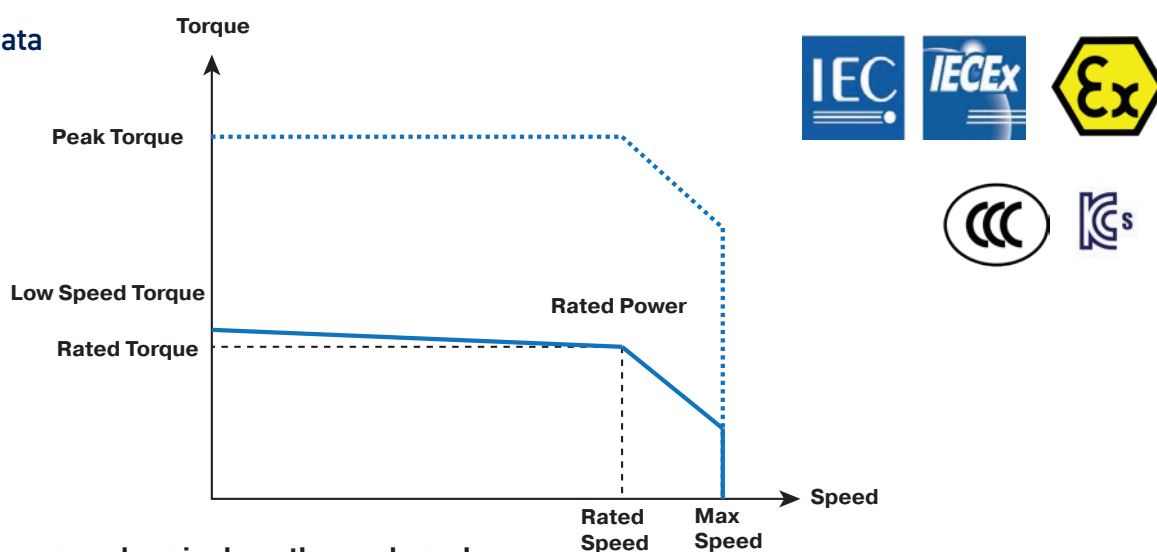

### 230 VAC power supply - single or three-phased

Motor	Rated Power P <sub>n</sub>	Rated Torque M <sub>n</sub>	Rated Speed N <sub>n</sub>	Rated Current I <sub>n</sub>	Low speed torque M <sub>0</sub>	Low Speed Current I <sub>0</sub>	Peak Torque M <sub>peak</sub>	Peak Current I <sub>peak</sub>	Max. Speed N <sub>max</sub>
	[kW]	[Nm]	[rpm]	[Arms]	[Nm]	[Arms]	[Nm]	[Arms]	[rpm]
<b>40°C ambient temperature</b>									
EX310EAP	0.40	1.66	2300	1.2	1.75	1.2	4.2	3.1	2300
EX310EAK	0.64	1.54	4000	2.0	1.75	2.2	4.2	5.4	4000
EX420EAP	0.77	3.18	2300	2.3	3.5	2.5	8.3	6.2	2300
EX420EAJ	1.12	2.67	4000	3.3	3.5	4.3	8.3	10.7	4000
EX430EAL	1.02	4.2	2300	3.0	4.8	3.3	11.5	8.3	2300
EX430EAF	1.37	3.3	4000	4.1	4.8	5.8	11.5	14.5	4000
EX620EAV	0.76	6.6	1100	2.4	6.7	2.4	16.7	6.0	1100
EX620EAR	1.33	5.8	2200	4.0	6.7	4.5	16.7	11.2	2200
EX630EAR	1.43	9.4	1450	4.2	10.4	4.6	25.9	11.5	1450
EX630EAN	2.02	8.4	2300	5.7	10.4	6.9	25.9	17.3	2300
EX820EAR	2.57	11.2	2200	7.5	14	9.3	32.5	23.2	2200
EX840EAK	3.31	15.8	2000	9.4	24.5	14.3	58.2	35.6	2000
EX860EAJ	3.86	25.4	1450	11.5	35	15.7	83.3	39.2	1450
<b>60°C ambient temperature</b>									
EX310EAP	0.31	1.30	2300	0.9	1.5	1.2	4.2	3.1	2300
EX310EAK	0.40	0.95	4000	1.3	1.5	2.2	4.2	5.4	4000
EX420EAP	0.59	2.45	2300	1.8	3	2.1	7.3	5.3	2300
EX420EAJ	0.63	1.5	4000	1.9	3	3.7	7.3	9.1	4000
EX430EAL	0.82	3.4	2300	2.4	4.2	2.9	10.2	7.2	2300
EX430EAF	0.90	2.9	3000	3.6	4.2	5.1	10.2	12.7	4000
EX620EAV	0.63	5.5	1100	2.0	6	2.2	15.0	5.3	1100
EX620EAR	0.88	3.8	2200	2.8	6	4.1	15.0	9.9	2200
EX630EAR	1.12	7.35	1450	3.4	9	4.0	22.5	9.8	1450
EX630EAN	1.24	5.15	2300	3.7	9	6.1	22.5	14.7	2300
EX820EAR	1.65	8.5	1850	5.8	11	7.3	26.6	18.3	2200
EX840EAK	2.23	11.5	1850	6.9	21	12.2	51.0	30.6	2000
EX860EAJ	2.74	18.0	1450	8.3	31	13.9	75.1	34.8	1450

**400 VAC power supply - single or three-phased**

Motor	Rated Power Pn	Rated Torque Mn	Rated Speed Nn	Rated Current In	Low speed torque Mo	Low Speed Current Io	Peak Torque M peak	Peak Current I peak	Max. Speed N max
	[kW]	[Nm]	[rpm]	[Arms]	[Nm]	[Arms]	[Nm]	[Arms]	[rpm]
<b>40°C ambient temperature</b>									
EX310EAP	0.64	1.54	4000	1.1	1.75	1.2	4.2	3.1	4000
EX310EAK	0.87	1.23	6800	1.6	1.75	2.2	4.2	5.4	6800
EX420EAP	0.94	3	4000	2.1	3.5	2.5	8.3	6.2	3000
EX420EAJ	1.11	1.8	6000	2.3	3.5	4.3	8.3	10.7	6000
EX430EAL	1.37	3.3	4000	2.3	4.8	3.3	11.5	8.3	4000
EX430EAF	1.37	3.3	4000	4.1	4.8	5.8	11.5	14.5	5800
EX620EAV	1.25	6.0	2000	2.2	6.7	2.4	16.7	6.0	2000
EX620EAR	1.53	3.8	3900	2.7	6.7	4.5	16.7	11.2	3900
EX630EAR	2.19	7.8	2700	3.5	10.4	4.6	25.9	11.5	2700
EX630EAN	2.18	5.2	4000	3.8	10.4	6.9	25.9	17.3	4000
EX820EAR	2.84	7.5	3600	5.2	14	9.3	32.5	23.2	3900
EX840EAK	0.99	2.9	3300	2.1	24.5	14.3	58.2	35.6	3500
EX860EAJ	2.35	9.0	2500	4.4	35	15.7	83.3	39.2	2600
<b>60°C ambient temperature</b>									
EX310EAP	0.40	0.95	4000	0.7	1.5	1.2	4.2	3.1	4000
EX310EAK	0.40	0.95	4000	1.3	1.5	2.2	4.2	5.4	6800
EX420EAP	0.66	2.1	4000	1.5	3.0	2.1	7.3	5.3	3000
EX420EAJ	0.63	1.5	4000	1.9	3.0	3.7	7.3	9.1	6000
EX430EAL	0.90	2.9	3000	2.0	4.2	2.9	10.2	7.2	4000
EX430EAF	0.90	2.9	3000	3.6	4.2	5.1	10.2	12.7	4900
EX620EAV	0.88	4.2	2000	1.6	6.0	2.2	15.0	5.3	2000
EX620EAR	0.84	3.2	2500	2.4	6.0	4.1	15.0	9.9	3900
EX630EAR	1.18	4.5	2500	2.2	9.0	4.0	22.5	9.8	2700
EX630EAN	1.18	4.5	2500	3.3	9.0	6.1	22.5	14.7	4000
EX820EAR	1.65	8.5	1850	5.8	11.0	7.3	26.6	18.3	3900
EX840EAK	2.22	11.5	1850	6.9	21.0	12.2	51.0	30.6	2600
EX860EAJ	2.60	15.5	1600	7.2	31.0	13.9	75.1	34.8	2100

## Drive Associations

### 230 VAC power supply

Motor	Associated Drive Sizes <sup>(1)</sup>			
	PSD1 <sup>(2)</sup>	Compax3	SLVD-N	AC890
<b>With 40°C ambient temperature - 230 VAC power supply</b>				
EX310EAP	PSD1SW1200...	C3S025V2...	SLVD2N...	890SD-231300B...
EX310EAK	PSD1SW1300...	C3S025V2...	SLVD5N...	890SD-231300B...
EX420EAP	PSD1SW1300...	C3S025V2...	SLVD5N...	890SD-231550B...
EX420EAJ	PSD1SW1300...	C3S063V2...	SLVD5N...	890SD-231700B...
EX430EAL	PSD1SW1300...	C3S063V2...	SLVD5N...	890SD-231550B...
EX430EAF	-	C3S063V2...	SLVD7N...	890SD-231700B...
EX620EAV	PSD1SW1300...	C3S025V2...	SLVD5N...	890SD-231550B...
EX620EAR	PSD1SW1300...	C3S063V2...	SLVD5N...	890SD-231700B...
EX630EAR	PSD1SW1300...	C3S063V2...	SLVD5N...	890SD-231700B...
EX630EAN	-	C3S100V2...	SLVD7N...	890SD-232110B...
EX820EAR	-	C3S100V2...	SLVD10N...	890SD-232165B...
EX840EAK	-	C3S150V2...	SLVD15N...	890SD-232240C...
EX860EAJ	-	-	-	890SD-232240C...
<b>With 60°C ambient temperature - 230 VAC power supply</b>				
EX310EAP	PSD1SW1200...	C3S025V2...	SLVD2N...	890SD-231300B...
EX310EAK	PSD1SW1300...	C3S025V2...	SLVD5N...	890SD-231300B...
EX420EAP	PSD1SW1300...	C3S025V2...	SLVD5N...	890SD-231300B...
EX420EAJ	PSD1SW1300...	C3S063V2...	SLVD5N...	890SD-231550B...
EX430EAL	PSD1SW1300...	C3S063V2...	SLVD5N...	890SD-231550B...
EX430EAF	-	C3S063V2...	SLVD7N...	890SD-231700B...
EX620EAV	PSD1SW1300...	C3S025V2...	SLVD5N...	890SD-231300B...
EX620EAR	PSD1SW1300...	C3S063V2...	SLVD5N...	890SD-231700B...
EX630EAR	PSD1SW1300...	C3S063V2...	SLVD5N...	890SD-231550B...
EX630EAN	-	C3S063V2...	SLVD7N...	890SD-232110B...
EX820EAR	-	C3S100V2...	SLVD10N...	890SD-232110B...
EX840EAK	-	C3S150V2...	SLVD15N...	890SD-232240C...
EX860EAJ	-	C3S150V2...	SLVD15N...	890SD-232240C...

<sup>(1)</sup>Ambient temperature for the drives is 40°C

<sup>(2)</sup>PSD drive with optional resolver board only

**400 VAC power supply**

Motor	Associated Drive Sizes <sup>(1)</sup>			
	PSD1 <sup>(2)</sup>	Compax3	AC890	AC30V
<b>With 40°C ambient temperature - 400 VAC power supply</b>				
EX310EAP	PSD1MW1300...	C3S015V4...	890SD-531200B...	31V-4D-0004
EX310EAK	PSD1MW1300...	C3S038V4...	890SD-531350B...	31V-4D-0004
EX420EAP	PSD1MW1300...	C3S038V4...	890SD-531350B...	31V-4D-0004
EX420EAJ	PSD1MW1300...	C3S075V4...	890SD-532100B...	31V-4D-0006
EX430EAL	PSD1MW1300...	C3S038V4...	890SD-531450B...	31V-4D-0005
EX430EAF	PSD1MW1400...	C3S075V4...	890SD-532100B...	31V-4D-0008
EX620EAV	PSD1MW1300...	C3S038V4...	890SD-531350B...	31V-4D-0004
EX620EAR	PSD1MW1300...	C3S075V4...	890SD-532100B...	31V-4D-0006
EX630EAR	PSD1MW1300...	C3S075V4...	890SD-532100B...	31V-4D-0008
EX630EAN	PSD1MW1400...	C3S150V4...	890SD-532120B...	31V-4D-0010
EX820EAR	PSD1MW1600...	C3S150V4...	890SD-532160B...	31V-4D-0012
EX840EAK	PSD1MW1600...	C3S150V4...	890SD-53216SB...	31V-4E-0023
EX860EAJ	PSD1MW1800...	C3S300V4...	890SD-53216SB...	31V-4E-0023
<b>With 60°C ambient temperature - 400 VAC power supply</b>				
EX310EAP	PSD1MW1300...	C3S015V4...	890SD-531200B...	31V-4D-0004
EX310EAK	PSD1MW1300...	C3S038V4...	890SD-531350B...	31V-4D-0004
EX420EAP	PSD1MW1300...	C3S038V4...	890SD-531350B...	31V-4D-0004
EX420EAJ	PSD1MW1300...	C3S038V4...	890SD-531600B...	31V-4D-0005
EX430EAL	PSD1MW1300...	C3S038V4...	890SD-531450B...	31V-4D-0004
EX430EAF	PSD1MW1400...	C3S075V4...	890SD-532100B...	31V-4D-0008
EX620EAV	PSD1MW1300...	C3S038V4...	890SD-531350B...	31V-4D-0004
EX620EAR	PSD1MW1300...	C3S075V4...	890SD-532100B...	31V-4D-0006
EX630EAR	PSD1MW1300...	C3S075V4...	890SD-531600B...	31V-4D-0006
EX630EAN	PSD1MW1400...	C3S075V4...	890SD-532120B...	31V-4D-0008
EX820EAR	PSD1MW1400...	C3S075V4...	890SD-532120B...	31V-4D-0010
EX840EAK	PSD1MW1600...	C3S150V4...	890SD-53216SB...	31V-4E-0016
EX860EAJ	PSD1MW1600...	C3S150V4...	890SD-53216SB...	31V-4E-0023

<sup>(1)</sup>Ambient temperature for the drives is 40°C

<sup>(2)</sup>PSD drive with optional resolver board only

## Dimensions (Resolver Version)

### EX3

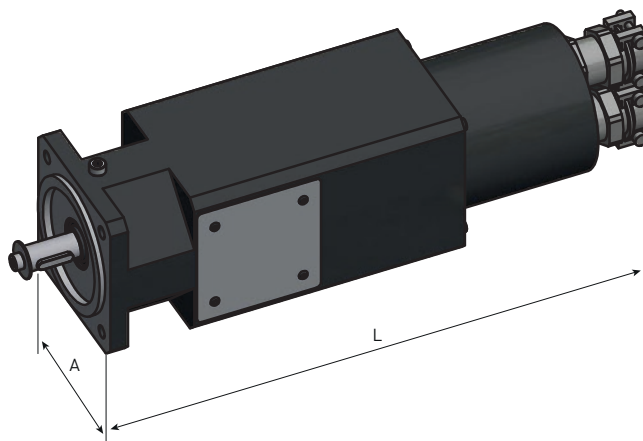

Motor	A	Mounting Flange centering / interaxis hole	Shaft diameter x length	Without Brake		With Brake	
	[mm]			[mm]	L [mm]	Weight [kg]	L [mm]
EX310	70	60 / 75	11 x 23	225	2.8	255	3.2

### EX4

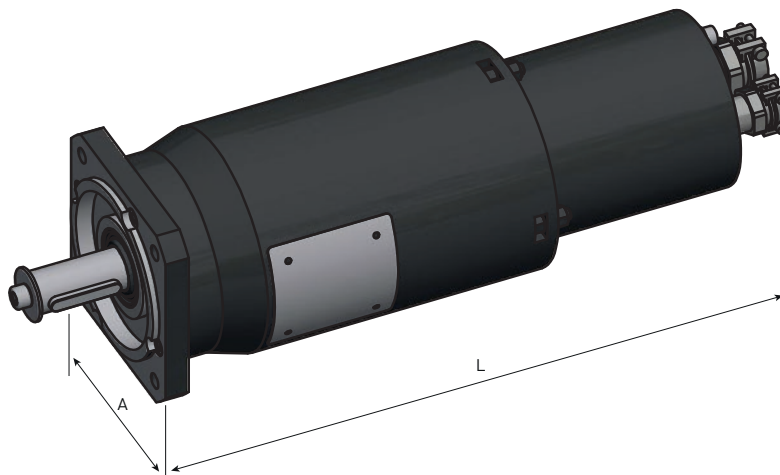

Motor	A	Mounting Flange centering / interaxis hole	Shaft diameter x length	Without Brake		With Brake	
	[mm]			[mm]	[mm]	Weight [kg]	L [mm]
EX420	92	80 / 100	19 x 40	305	7	330	8
EX430				330	8	355	9



**EX6**

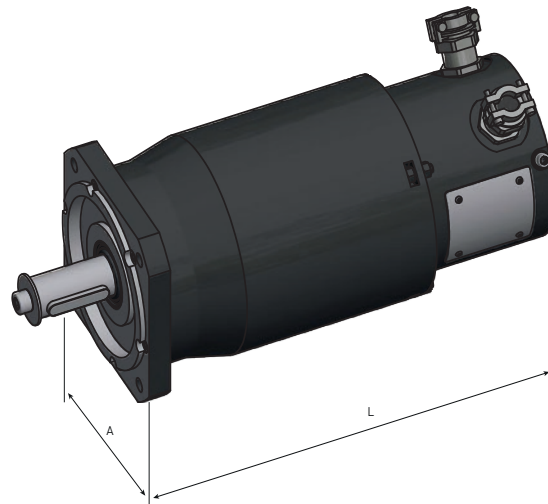

Motor	A	Mounting Flange centering / interaxis hole	Shaft diameter x length	Without Brake		With Brake	
	[mm]			[mm]	L [mm]	Weight [kg]	L [mm]
EX620	120	110 / 130	24 x 50	275	10	290	11
EX630				300	12.5	325	13.5

**EX8**



Motor	A	Mounting Flange centering / interaxis hole	Shaft diameter x length	Without Brake		With Brake	
	[mm]			[mm]	L [mm]	Weight [kg]	L [mm]
EX820	155	130 / 165	32 x 58	325	22	360	25
EX840				385	28	420	31
EX860				445	38	480	41

## Order Code

### EX Motors - CE Marked

	1	2	3	4	5	6	7	8	9	10	11	12
Order example	<b>EX</b>	<b>3</b>	<b>10</b>	<b>E</b>	<b>A</b>	<b>P</b>	<b>B</b>	<b>1</b>	<b>2</b>	<b>1</b>	<b>1</b>	<b>-</b>

<b>1</b>	<b>Product Series</b>	
	<b>EX</b>	Atex servo motor Zone 1
<b>2</b>	<b>Motor size</b>	
	<b>3</b>	70 mm square
	<b>4</b>	92 mm square
	<b>6</b>	120 mm square
	<b>8</b>	155 mm square
<b>3</b>	<b>Motor length</b>	
	<b>10</b>	up to 60 depending on size
<b>4</b>	<b>Fixed code</b>	
	<b>E</b>	ATEX/IECEX/KOSHA/CCC motor
<b>5</b>	<b>Feedback sensor</b>	
	<b>A</b>	2 pole resolver (standard)
	<b>K</b>	Without feedback sensor
	<b>P</b>	Absolute singleturn HIPERFACE DSL® EKS36 Encoder
	<b>Q</b>	Absolute multiturn HIPERFACE DSL® EKM36 Encoder
	<b>R</b>	Absolute singleturn HIPERFACE SKS36 Encoder (128 periods/rev)
	<b>S</b>	Absolute multiturn HIPERFACE SKM36 Encoder (128 periods/rev)
<b>6</b>	<b>Torque/Speed characteristics</b>	
		see table "Technical data"
	...	
<b>7</b>	<b>Painting</b>	
	<b>B</b>	Black RAL9005
<b>8</b>	<b>Electric connection</b>	
	<b>1</b>	Cable gland
<b>9</b>	<b>Brake</b>	
	<b>2</b>	Motor without brake (standard) + thermal switch sensor
	<b>5</b>	Motor with brake + thermal switch sensor
<b>10</b>	<b>Ingress protection level</b>	
	<b>1</b>	IP65
<b>11</b>	<b>Shaft end</b>	
	<b>0</b>	Smooth shaft (standard)
	<b>1</b>	Key shaft
<b>12</b>	<b>Nameplate</b>	
	<b>-</b>	ATEX/IECEX/KOSHA
	<b>C</b>	CCC certification

## Cables

### Motor cable

Drive	Cable reference	
	Current ≤ 12 A @40°C ambient t° Current ≤ 9 A @60°C ambient t°	Current ≤ 24 A @40°C ambient t° Current ≤ 17 A @60°C ambient t°
<b>Cable for use with Hiperface DSL® feedback (single cable)</b>		
<b>PSD1S, PSD1M18</b>	CBM015TD-T03-D01-xxxx-00	-
<b>PSD1M (except M18)</b>	CBM015TD-T03-D02-xxxx-00	-
<b>Cable for use with other feedback</b>		
<b>PSD1</b>	Consult us	
<b>Compax3</b>	CC3UQ1D1Rxxxx	CC3UQ2D1Rxxxx
<b>SLVDN</b>	CS5UQ1D1R0xxx	CS5UQ2D1R0xxx
<b>AC890</b>	CS4UQ1D1Rxxxx	CS4UQ2D1Rxxxx

### Feedback cable

Drive	Cable reference	
	2 pole resolver	Hiperface
<b>PSD1</b>	CBFRE0T0-T05-D03-xxxx-00	-
<b>Compax3</b>	CC3UA1D1Rxxxx	CC3UR1D1Rxxxx
<b>SLVDN</b>	CS5UA1D1R0xxx	-
<b>AC890</b>	CS4UA1D1Rxxxx	-

For non-standard length cable with length different from: 3/5/10/15/20/25/30/50m please contact us.

To note that these cables have a surface temperature resistance of 100°C.

## Additional Information

### Feedback Sensors

#### 2 poles resolver - option A

- Accuracy:  $\pm 10'$  max
- Transformation ratio:  $0.5 \pm 5\%$
- Max. operating speed:  $17\,000\text{ min}^{-1}$
- Working temperature range:  $-55\dots+155\text{ }^\circ\text{C}$

#### Single turn / Multiturn absolute encoder HIPERFACE SKS/SKM36 - option R/S

- Number of sine/cosine periods per revolution: 128
- Absolute position per revolution: 4096 (12 bits)
- Number of absolutely encodable revolutions: 4096 (SKM36)
- Max. operating speed SKS36:  $12\,000\text{ min}^{-1}$
- Max. operating speed SKM36:  $9\,000\text{ min}^{-1}$
- Working temperature range:  $-20\dots+110\text{ }^\circ\text{C}$

#### Single turn / Multiturn absolute encoder HIPERFACE DSL® EKS/EKM36 - option P/Q

- Absolute position per revolution: 4096 (18/20 bits)
- Number of absolutely encodable revolutions: 4096 (EKM36)
- Max. operating speed EKS36:  $12\,000\text{ min}^{-1}$
- Max. operating speed EKM36:  $9\,000\text{ min}^{-1}$
- Working temperature range:  $-20\dots+115\text{ }^\circ\text{C}$
- SIL2 certified

### Shaft Loads for CE Motors

#### Maximum load acceptable on the shaft

The values written in the table are given for a load placed on the middle of the shaft like the picture below.

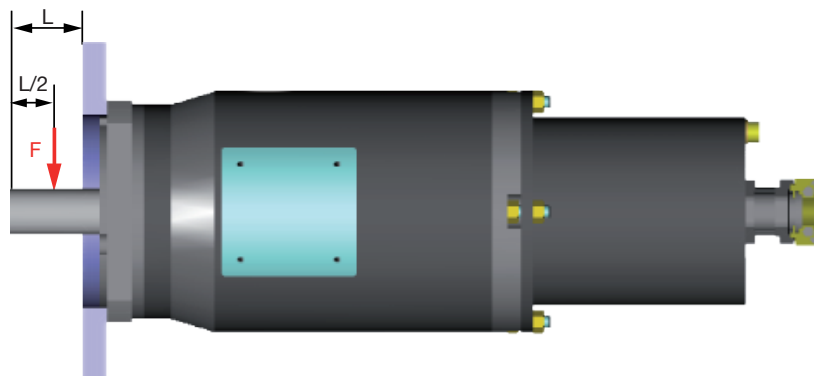

Due to the small ATEX airgap requirements between the shaft and the front flange, the radial loads on the shaft are lower than standard NX motors.

The ATEX airgap requirements depend on the volume of the motor and can lead to lower radial loads for bigger motors.

Regarding to these shaft loads, you must not use a pulley belt system without a load take-up system.

Type	Max. shaft load F [N]
EX310	100
EX430	500
EX630	500
EX860	250





# ATEX Gearboxes GXA Series

## Overview

### Description

GXA gearbox series has to be associated with the powerful Parker ATEX servomotors ranges for use in hazardous areas. The precision helical gearing design offers smooth and quiet operation for the most demanding high performance applications. The solid uncaged needle roller bearings provides maximum contact points to increase stiffness and generates high output torque. In addition the unique motor adapter and bushing module system design allows to obtain a compact structure and a quick and easy mounting of any ATEX certified Parker motor.

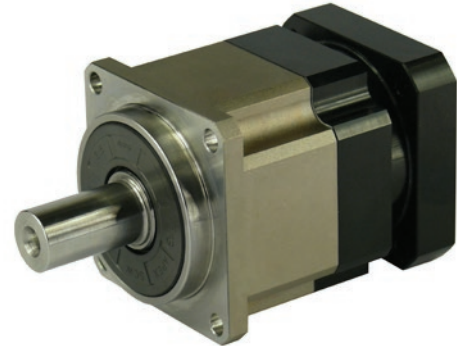

### Features

- ATEX certify
- Low backlash
- High efficiency
- Easy mounting
- Low noise
- Compact structure
- Helical Gear Design



### Technical Characteristics - Overview

Series	Unit	GXA
<b>Gear geometry</b>		Helical Gearing
<b>Type</b>		In-Line
<b>Frame sizes</b>	[mm]	60, 90, 115, 142, 180, 220
<b>Maximum input speed</b>	[min <sup>-1</sup> ]	up to 10 000
<b>Nominal torque</b>	[Nm]	40...1800
<b>Radial force</b>	[N]	up to 50 000
<b>Life</b>	[h]	up to 20 000
<b>Backlash</b>	[arcmin]	up to ≤ 3
<b>Efficiency</b>	[%]	up to ≥ 97 %
<b>Conformance</b>		2014/34/EU Directive
<b>Classification</b>		II 2 GD c T6
<b>Harmonized standard</b>		EN 1127-1:2012
<b>Other technical standards &amp; specifications applied</b>		EN 13463-1:2009, EN 13463-5:2013, ISO281:2004, ISO286:2013, DIN3960

## Technical Characteristics

Model No.		Stage	Ratio <sup>1</sup>	GX.. R02..	GX.. R04..	GX.. R06..	GX.. R07..	GX.. R09..	GX.. R10..
<b>Nominal Output Torque T<sub>2N</sub></b>	<b>[Nm]</b>	1	3	55	130	208	342	588	-
			4	50	140	290	542	1050	-
			5	60	160	330	650	1200	-
			6	55	150	310	600	1100	-
			7	50	140	300	550	1100	-
			8	45	120	260	500	1000	-
			9	40	100	230	450	900	-
		10	40	100	230	450	900	-	
		2	15	-	130	208	342	588	-
			20	-	140	290	542	1050	-
			25	-	160	330	650	1200	-
			30	-	150	310	600	1100	-
			35	-	140	300	550	1100	-
			40	-	120	260	500	1000	-
			45	-	100	230	450	900	-
			50	-	160	330	650	1200	-
			60	-	150	310	600	1100	-
			70	-	140	300	550	1100	1800
			80	-	120	260	500	1000	1600
			90	-	100	230	450	900	1500
100	-		100	230	450	900	1500		
<b>Emergency Stop Torque T<sub>2NOT</sub><sup>3</sup></b>	<b>[Nm]</b>	1,2	3~100	3 times of Nominal Output Torque					
<b>Nominal Input Speed n<sub>1N</sub></b>	<b>[min<sup>-1</sup>]</b>	1,2	3~100	5000	4000	4000	3000	3000	2000
<b>Max. Input Speed n<sub>1B</sub></b>	<b>[min<sup>-1</sup>]</b>	1,2	3~100	10 000	8000	8000	6000	6000	4000
<b>Standard Backlash</b>	<b>[arcmin]</b>	1	3~10	≤ 5	≤ 5	≤ 5	≤ 5	≤ 5	≤ 5
		2	15~100	≤ 7	≤ 7	≤ 7	≤ 7	≤ 7	≤ 7
<b>Reduced Backlash</b>	<b>[arcmin]</b>	1	3~10	≤ 3	≤ 3	≤ 3	≤ 3	≤ 3	≤ 3
		2	15~100	≤ 5	≤ 5	≤ 5	≤ 5	≤ 5	≤ 5
<b>Torsional Rigidity</b>	<b>[Nm / arcmin]</b>	1,2	3~100	7	14	25	50	145	225
<b>Max. Radial Load F<sub>2rB</sub><sup>2</sup></b>	<b>[N]</b>	1,2	3~100	1530	3250	6700	9400	14500	50000
<b>Max. Axial Load F<sub>2aB</sub><sup>2</sup></b>	<b>[N]</b>	1,2	3~100	765	1625	3350	4700	7250	25000
<b>Lifetime</b>	<b>[h]</b>	1,2	3~100	20 000*					
<b>Efficiency</b>	<b>[%]</b>	1	3~10	≥ 97 %					
		2	15~100	≥ 94 %					
<b>Weight</b>	<b>[kg]</b>	1	3~10	1.3	3.7	7.8	14.5	29	48
		2	15~100	1.5	4.1	9	17.5	33	60
<b>Operating Temp</b>	<b>[°C]</b>	1,2	3~100	-10 to 40 °C					
<b>Lubrication</b>				Synthetic grease					
<b>Degree of Gearbox Protection</b>		1,2	3~100	IP65					
<b>Mounting Position</b>		1,2	3~100	All directions					
<b>Noise Level (n<sub>1</sub>=3000 min<sup>-1</sup>, No Load)</b>	<b>[dB(A)]</b>	1,2	3~100	≤ 58	≤ 60	≤ 63	≤ 65	≤ 67	≤ 70

<sup>1</sup> Ratio ( i=N in / N out )

<sup>2</sup> Applied to the output shaft center @ 100 min<sup>-1</sup>

<sup>3</sup> Max. acceleration torque T<sub>2B</sub> = 60% of T<sub>2NOT</sub>

\*S1 service life 10,000 hrs.



## Gearbox Inertia

Model No.	Unit	Stage	Ratio	GX.. R02..	GX.. R04..	GX.. R06..	GX.. R07..	GX.. R09..	GX.. R10..
<b>Mass Moments of inertia J<sub>1</sub></b>	[kgmm <sup>2</sup> ]	1	3	16	61	325	921	2898	-
			4	14	48	274	754	2367	-
			5	13	47	271	742	2329	-
			6	13	45	265	725	2275	-
			7	13	45	262	714	2248	-
			8	13	44	258	707	2259	-
			9	13	44	257	704	2253	-
			10	13	44	257	703	2251	-
		2	15	-	13	47	271	742	-
			20	-	13	47	271	742	-
			25	-	13	47	271	742	-
			30	-	13	47	271	742	-
			35	-	13	47	271	742	-
			40	-	13	47	271	742	-
			45	-	13	47	271	742	-
			50	-	13	44	257	703	-
			60	-	13	44	257	703	-
			70	-	13	44	257	703	2251
			80	-	13	44	257	703	2251
			90	-	13	44	257	703	2251
100	-	13	44	257	703	2251			

### Permitted radial and axial loads on output shaft of the gearbox

The permitted radial and axial loads on output shaft of the gearbox depend on the design of the gearbox supporting bearings. GXA Series uses the extension straddle oversized ball bearing design. It can take heavy load from both axes.

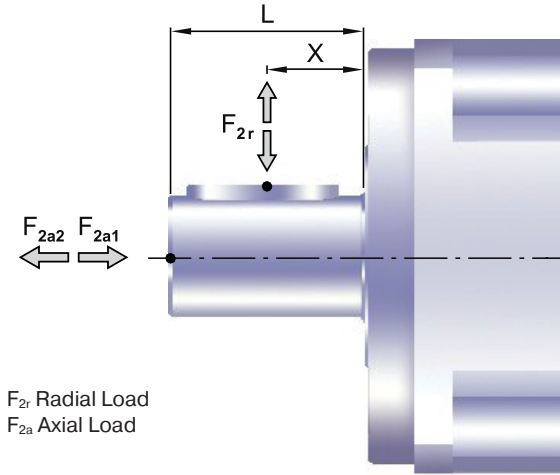

If radial force  $F_{2r}$  exert on the center of the output shaft :  $X=1/2 \times L$ .

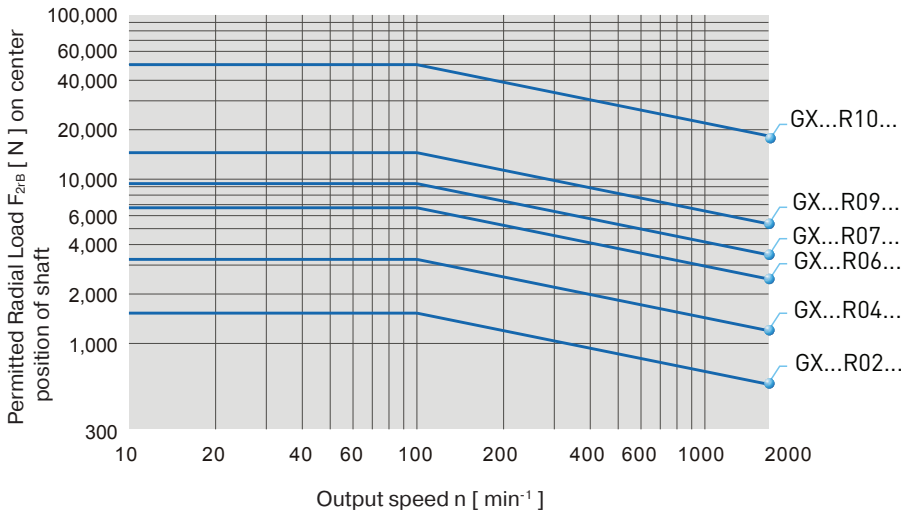

The permitted radial load is given on left diagram.

If radial force  $F_{2r}$  not exert on the center of the output shaft :  $X < 1/2 \times L$  or  $X > 1/2 \times L$

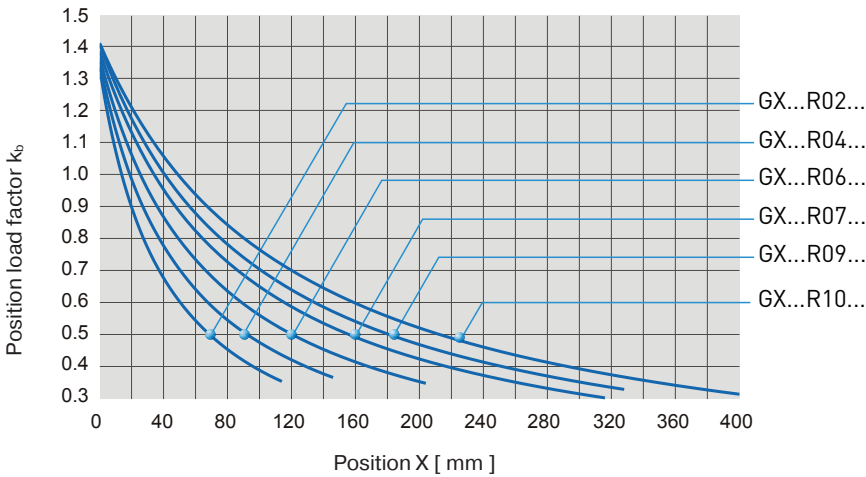

The permitted radial load can be calculated by multiplying the previous value by the position load factor  $k_b$  on the left diagram.

## Dimensions

1 Stage - Ratio  $i = 3 - 10$

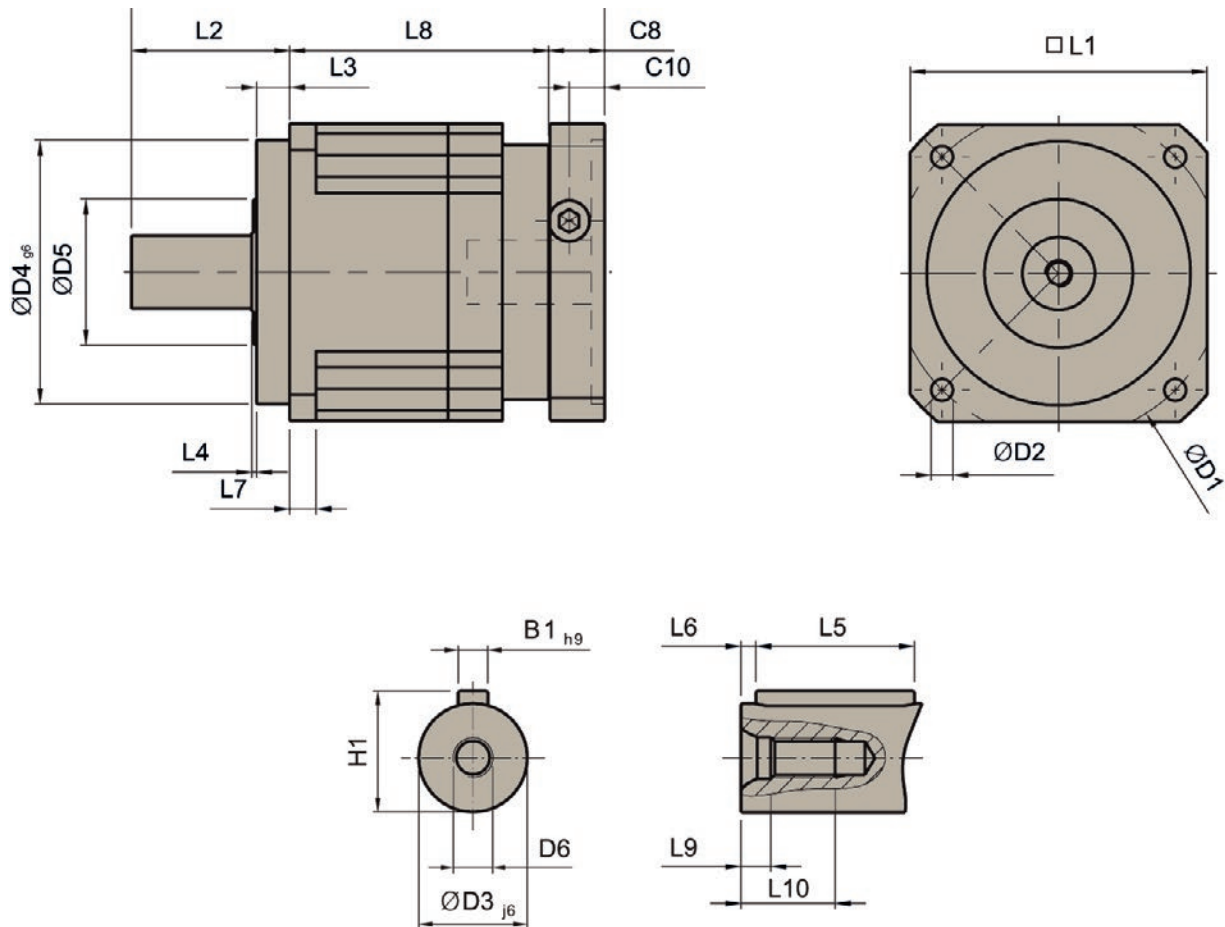

	GX..R02..	GX..R04..	GX..R06..	GX..R07..	GX..R09..
<b>D1</b>	70	100	130	165	215
<b>D2</b>	5.5	6.6	9	11	13
<b>D3 j6</b>	16	22	32	40	55
<b>D4 g6</b>	50	80	110	130	160
<b>D5</b>	45	65	95	75	95
<b>D6</b>	M5 x 0.8	M8 x 1.25	M12 x 1.75	M16 x 0.8	M20 x 2.5
<b>L1</b>	60	90	115	142	180
<b>L2</b>	37	48	65	97	105
<b>L3</b>	7	10	12	15	20
<b>L4</b>	1.5	1.5	2	3	3
<b>L5</b>	25	32	40	63	70
<b>L6</b>	2	3	5	5	6
<b>L7</b>	6	8	10	12	15
<b>L8</b>	61	78.5	102	119.5	154
<b>L9</b>	4.8	7.2	10	12	15
<b>L10</b>	12.5	19	28	36	42
<b>C8 <sup>3</sup></b>	19	17	19.5	22.5	29
<b>C10 <sup>3</sup></b>	13.5	10.75	13	15	20.75
<b>B1 <sub>h9</sub></b>	5	6	10	12	16
<b>H1</b>	18	24.5	35	43	59

<sup>3</sup>C8-C10 are motor specific dimensions.

2 Stages - Ratio  $i = 15 - 100$

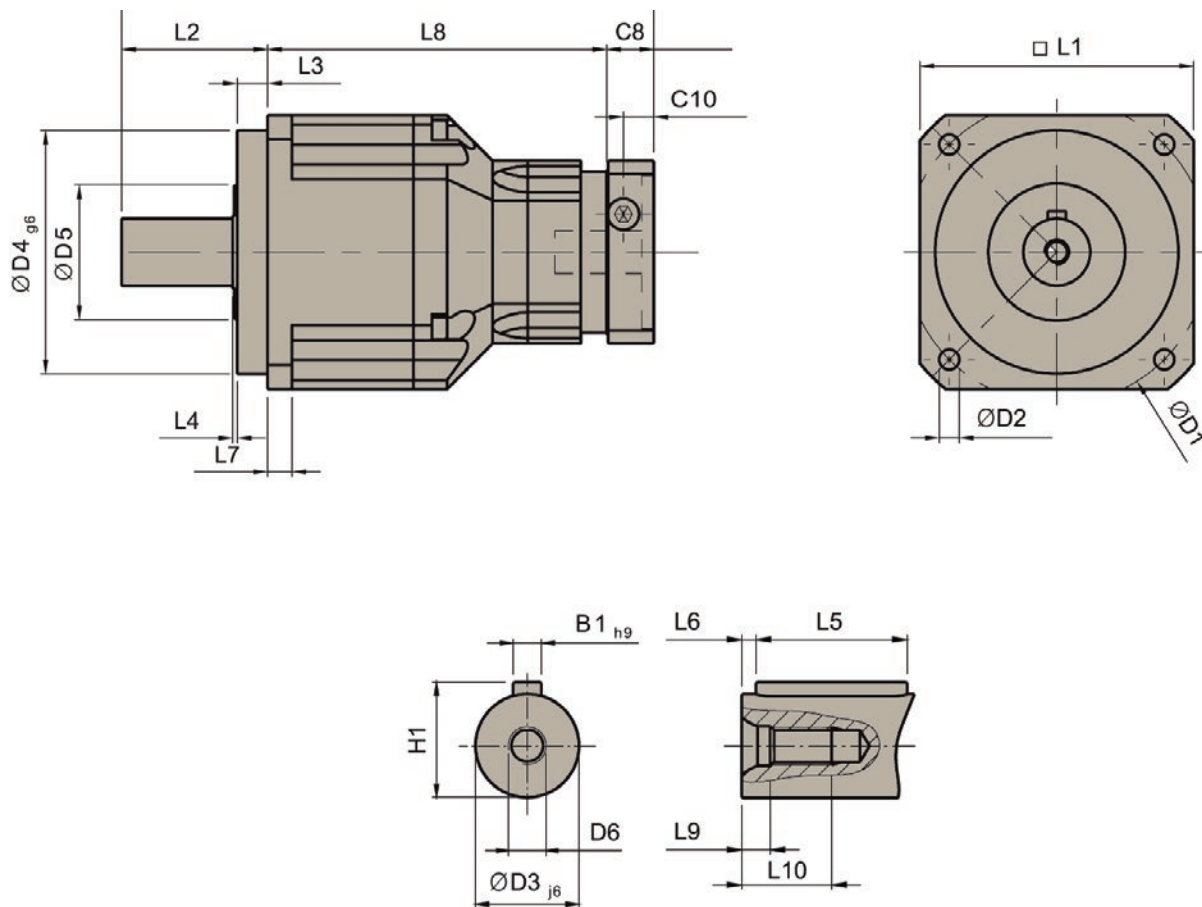

	GX..R04..	GX..R06..	GX..R07..	GX..R09..	GX..R10..
<b>D1</b>	100	130	165	215	250
<b>D2</b>	6.6	9	11	13	17
<b>D3 j6</b>	22	32	40	55	75
<b>D4 g6</b>	80	110	130	160	180
<b>D5</b>	65	95	75	95	115
<b>D6</b>	M8 x 1.25	M12 x 1.75	M16 x 2	M20 x 2.5	M20 x 2.5
<b>L1</b>	90	115	142	180	220
<b>L2</b>	48	65	97	105	138
<b>L3</b>	10	12	15	20	30
<b>L4</b>	1.5	2	3	3	3
<b>L5</b>	32	40	63	70	90
<b>L6</b>	3	5	5	6	7
<b>L7</b>	8	10	12	15	20
<b>L8</b>	111.5	143.5	176	209.5	248
<b>L9</b>	7.2	10	12	15	15
<b>L10</b>	19	28	36	42	42
<b>C8 <sup>4</sup></b>	19	17	19.5	22.5	29
<b>C10 <sup>4</sup></b>	13.5	10.75	13	15	20.75
<b>B1 h9</b>	6	10	12	16	20
<b>H1</b>	24.5	35	43	59	79.5

4. C8~C10 are motor specific dimensions.

## Gearbox Combinations

	Ratio	Motor Size				
		EX3 / EY3	EX4 / EY4	EX6 / EY6	EX8 / EY8	
<b>1 stage</b>	3	GXA3N003R0201	GXA4N003R0401	GXA6N003R0601	GXA8N003R0701	
	4	GXA3N004R0201	GXA4N004R0401	GXA6N004R0601	GXA8N004R0701	
	5	GXA3N005R0201	GXA4N005R0401	GXA6N005R0601	GXA8N005R0701	
	6	GXA3N006R0201	GXA4N006R0401	GXA6N006R0601	GXA8N006R0701	
	7	GXA3N007R0201	GXA4N007R0401	GXA6N007R0601	GXA8N007R0701	
	8	GXA3N008R0201	GXA4N008R0401	GXA6N008R0601	GXA8N008R0701	
	9	GXA3N009R0201	GXA4N009R0401	GXA6N009R0601	GXA8N009R0701	
	10	GXA3N010R0201	GXA4N010R0401	GXA6N010R0601	GXA8N010R0701	
<b>2 stages</b>	15	GXA3N015R0401	GXA4N015R0601	GXA6N015R0701	GXA8N015R0901	
	20	GXA3N020R0401	GXA4N020R0601	GXA6N020R0701	GXA8N020R0901	
	25	GXA3N025R0401	GXA4N025R0601	GXA6N025R0701	GXA8N025R0901	
	30	GXA3N030R0401	GXA4N030R0601	GXA6N030R0701	GXA8N030R0901	
	35	GXA3N035R0401	GXA4N035R0601	GXA6N035R0701	GXA8N035R0901	
	40	GXA3N040R0401	GXA4N040R0601	GXA6N040R0701	GXA8N040R0901	
	45	GXA3N045R0401	GXA4N045R0601	GXA6N045R0701	GXA8N045R0901	
	50	GXA3N050R0401	GXA4N050R0601	GXA6N050R0701	GXA8N050R0901	
	60	GXA3N060R0401	GXA4N060R0601	GXA6N060R0701	GXA8N060R0901	
	70			GXA4N070R0601		GXA8N070R0901
		GXA3N070R0401	GXA4N070R0701	GXA6N070R0701	GXA8N070R1001	
	80	GXA3N080R0401	GXA4N080R0601	GXA6N080R0701	GXA8N080R0901	
			GXA4N080R0701		GXA8N080R1001	
	90	GXA3N090R0401	GXA4N090R0601	GXA6N090R0701	GXA8N090R0901	
			GXA4N090R0701		GXA8N090R1001	
	100	GXA3N100R0401	GXA4N100R0601	GXA6N100R0701		
		GXA4N100R0701		GXA8N100R1001		

Motor gearhead possible combination with torque limitation, please consult us at [EM-motion@parker.com](mailto:EM-motion@parker.com)

## Order Code

### GXA Gearboxes

	1	2	3	4	5	6	7
Order example	<b>GX</b>	<b>A</b>	<b>3</b>	<b>N</b>	<b>005</b>	<b>R060</b>	<b>0</b>

<b>1 Gearbox Series</b>	<b>GX</b>	Gearbox for in-line mounting
<b>2 Gearbox Type</b>	<b>A</b>	ATEX version
<b>3 Motor size association *</b>	<b>3</b>	EX3, EY3 (60/75/11/23)
	<b>4</b>	EX4, EY4 (80/100/19/40)
	<b>6</b>	EX6, EY6 (110/130/24/50)
	<b>8</b>	EX8, EY8 (130/165/32/58)
<b>4 Backlash</b>	<b>N</b>	Normal
	<b>R</b>	Reduced
<b>5 Ratio</b>	<b>3 to 10</b>	for GXA 1 stage
	<b>15 to 100</b>	for GXA 2 stages
<b>6 Gearbox Size *</b>	<b>R020</b>	Size 60
	<b>R040</b>	Size 90
	<b>R060</b>	Size 115
	<b>R070</b>	Size 142
	<b>R090</b>	Size 180
	<b>R100</b>	Size 220
<b>7 Shaft</b>	<b>0</b>	Smooth shaft
	<b>1</b>	Keyed shaft

\* To find out about possible combinations please refer to the table on page 37.



# Parker's Motion & Control Technologies

At Parker, we're guided by a relentless drive to help our customers become more productive and achieve higher levels of profitability by engineering the best systems for their requirements. It means looking at customer applications from many angles to find new ways to create value. Whatever the motion and control technology need, Parker has the experience, breadth of product and global reach to consistently deliver. No company knows more about motion and control technology than Parker. For further info call 00800 27 27 5374



## Aerospace

### Key Markets

Aftermarket services  
Commercial transports  
Engines  
General & business aviation  
Helicopters  
Launch vehicles  
Military aircraft  
Missiles  
Power generation  
Regional transports  
Unmanned aerial vehicles

### Key Products

Control systems & actuation products  
Engine systems & components  
Fluid conveyance systems & components  
Fluid metering, delivery & atomization devices  
Fuel systems & components  
Fuel tank inerting systems  
Hydraulic systems & components  
Thermal management  
Wheels & brakes



## Climate Control

### Key Markets

Agriculture  
Air conditioning  
Construction Machinery  
Food & beverage  
Industrial machinery  
Life sciences  
Oil & gas  
Precision cooling  
Process  
Refrigeration  
Transportation

### Key Products

Accumulators  
Advanced actuators  
CO<sub>2</sub> controls  
Electronic controllers  
Filter driers  
Hand shut-off valves  
Heat exchangers  
Hose & fittings  
Pressure regulating valves  
Refrigerant distributors  
Safety relief valves  
Smart pumps  
Solenoid valves  
Thermostatic expansion valves



## Electromechanical

### Key Markets

Aerospace  
Factory automation  
Life science & medical  
Machine tools  
Packaging machinery  
Paper machinery  
Plastics machinery & converting  
Primary metals  
Semiconductor & electronics  
Textile  
Wire & cable

### Key Products

AC/DC drives & systems  
Electric actuators, gantry robots & slides  
Electrohydraulic actuation systems  
Electromechanical actuation systems  
Human machine interface  
Linear motors  
Stepper motors, servo motors, drives & controls  
Structural extrusions



## Filtration

### Key Markets

Aerospace  
Food & beverage  
Industrial plant & equipment  
Life sciences  
Marine  
Mobile equipment  
Oil & gas  
Power generation & renewable energy  
Process  
Transportation  
Water Purification

### Key Products

Analytical gas generators  
Compressed air filters & dryers  
Engine air, coolant, fuel & oil filtration systems  
Fluid condition monitoring systems  
Hydraulic & lubrication filters  
Hydrogen, nitrogen & zero air generators  
Instrumentation filters  
Membrane & fiber filters  
Microfiltration  
Sterile air filtration  
Water desalination & purification filters & systems



## Fluid & Gas Handling

### Key Markets

Aerial lift  
Agriculture  
Bulk chemical handling  
Construction machinery  
Food & beverage  
Fuel & gas delivery  
Industrial machinery  
Life sciences  
Marine  
Mining  
Mobile  
Oil & gas  
Renewable energy  
Transportation

### Key Products

Check valves  
Connectors for low pressure fluid conveyance  
Deep sea umbilicals  
Diagnostic equipment  
Hose couplings  
Industrial hose  
Mooring systems & power cables  
PTFE hose & tubing  
Quick couplings  
Rubber & thermoplastic hose  
Tube fittings & adapters  
Tubing & plastic fittings



## Hydraulics

### Key Markets

Aerial lift  
Agriculture  
Alternative energy  
Construction machinery  
Forestry  
Industrial machinery  
Machine tools  
Marine  
Material handling  
Mining  
Oil & gas  
Power generation  
Refuse vehicles  
Renewable energy  
Truck hydraulics  
Turf equipment

### Key Products

Accumulators  
Cartridge valves  
Electrohydraulic actuators  
Human machine interfaces  
Hybrid drives  
Hydraulic cylinders  
Hydraulic motors & pumps  
Hydraulic systems  
Hydraulic valves & controls  
Hydrostatic steering  
Integrated hydraulic circuits  
Power take-offs  
Power units  
Rotary actuators  
Sensors



## Pneumatics

### Key Markets

Aerospace  
Conveyor & material handling  
Factory automation  
Life science & medical  
Machine tools  
Packaging machinery  
Transportation & automotive

### Key Products

Air preparation  
Brass fittings & valves  
Manifolds  
Pneumatic accessories  
Pneumatic actuators & grippers  
Pneumatic valves & controls  
Quick disconnects  
Rotary actuators  
Rubber & thermoplastic hose & couplings  
Structural extrusions  
Thermoplastic tubing & fittings  
Vacuum generators, cups & sensors



## Process Control

### Key Markets

Alternative fuels  
Biopharmaceuticals  
Chemical & refining  
Food & beverage  
Marine & shipbuilding  
Medical & dental  
Microelectronics  
Nuclear Power  
Offshore oil exploration  
Oil & gas  
Pharmaceuticals  
Power generation  
Pulp & paper  
Steel  
Water/wastewater

### Key Products

Analytical Instruments  
Analytical sample conditioning products & systems  
Chemical injection fittings & valves  
Fluoropolymer chemical delivery fittings, valves & pumps  
High purity gas delivery fittings, valves, regulators & digital flow controllers  
Industrial mass flow meters/controllers  
Permanent no-weld tube fittings  
Precision industrial regulators & flow controllers  
Process control double block & bleeds  
Process control fittings, valves, regulators & manifold valves



## Sealing & Shielding

### Key Markets

Aerospace  
Chemical processing  
Consumer  
Fluid power  
General Industrial  
Information technology  
Life sciences  
Microelectronics  
Military  
Oil & gas  
Power generation  
Renewable energy  
Telecommunications  
Transportation

### Key Products

Dynamic seals  
Elastomeric o-rings  
Electro-medical instrument design & assembly  
EMI shielding  
Extruded & precision-cut, fabricated elastomeric seals  
High temperature metal seals  
Homogeneous & inserted elastomeric shapes  
Medical device fabrication & assembly  
Metal & plastic retained composite seals  
Shielded optical windows  
Silicone tubing & extrusions  
Thermal management  
Vibration dampening

[www.parker.com](http://www.parker.com)



**European Headquarters**  
La Tuilière 6, 1163 Etoy,  
Switzerland  
Tel: +41 21 821 85 00

Your authorized distributor